

Robbins Precast

"Manufacturer of precast concrete products since 1974"



CHAMFER ON VERTICAL & TOP CORNERS
SIDES ARE RECESSED 1/2" x 9" x 25"

WEIGHS APPROX. 1100#

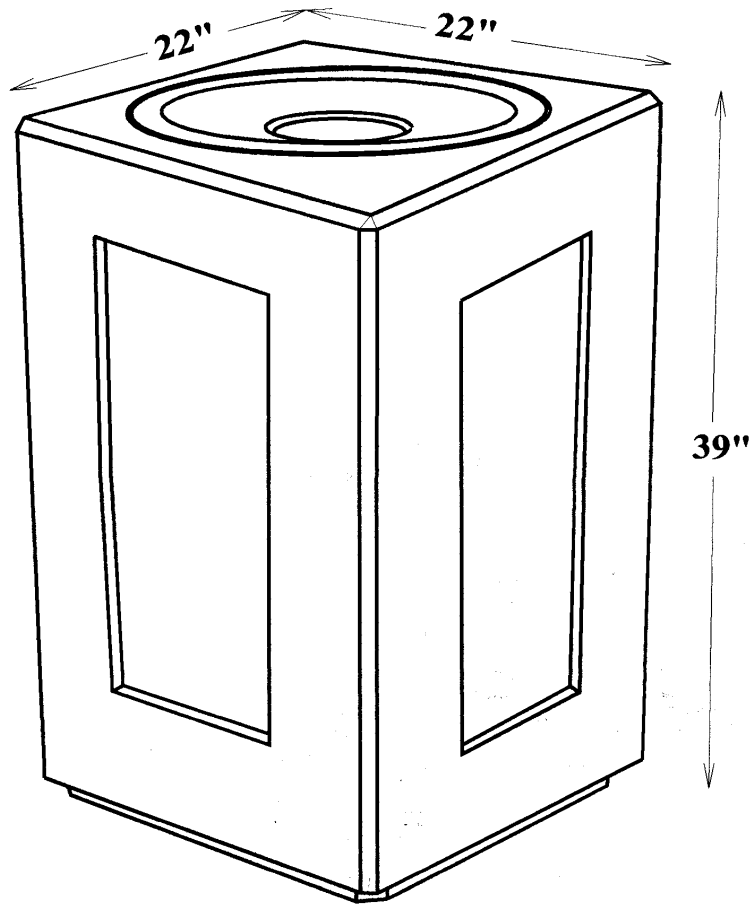

NuCast Industries, Inc.
23220 Park Canyon Dr
Corona, CA 92883
Tele 951-277-8888
Fax 951-277-8052
www.robbsinc.com
J32robbsins@earthlink.net

STR22

Concrete Receptacle

Available in various colors and surface finishes.
Steel reinforced. Chamfer on vertical & top corners.
Sides are recessed 1/2" x 9" x 25". Weighs approximately
1,100 lbs.